

LP2521

Single Port PoE Injector

Installation Guide

Purpose of Guide

This Guide provides information and procedures for the product installation and operation of the Single Port Power over Ethernet Injector. This document is intended for technical personnel responsible for installing and operating Power over Ethernet products in a Local Area Network (LAN) environment. To use this document effectively, you should have a working knowledge of Local Area Networking (LAN) concepts and hardware installation. In addition, you should be familiar with the following: Connection of Patch Cables with RJ45 connectors and the LAN addressing map for your particular Network, Mounting of Network hardware in a 19" equipment rack and local practices for power cord connections.

IMPORTANT SAFETY INSTRUCTIONS FROM LAN POWER SYSTEMS

Read and keep these instructions. Follow all instructions and heed all warnings. Do not use this equipment near water and clean only with a dry cloth. Do not block any equipment ventilation openings. Install in accordance with manufacturer's instructions. Do not install near any heat sources such as radiators, heat registers, stoves, or other apparatus (including amplifiers) that produce heat. Do not defeat the safety purpose of the polarized or grounding-type plug. A polarized plug has two blades with one wider than the other. A grounding plug has two blades and a third grounding prong. The wide blade or the third prong is provided for your safety. If the provided grounding prong does not fit into your outlet, consult an electrician for replacement of the obsolete outlet. Protect the power cord from being walked on or pinched particularly at plugs, convenience receptacles, and the point where they exit from the equipment. Unplug this equipment during lightning storms or when unused for long periods of time. Refer all servicing to qualified service personnel. Servicing is required when the equipment has been damaged in any way, such as power cord or plug damaged, liquid has been spilled, or object has fallen into the equipment, the equipment has been exposed to rain or moisture, does not operate normally, or has been dropped.

The AC mains plug, or appliance coupler shall be readily available to the operator as a means of power disconnection.

WARNING - Only connect equipment to mains power outlet having protective earthing or grounding connection. To reduce the risk of fire or electric shock, do not expose this equipment to rain or moisture. **CAUTION** - These servicing instructions are for use by qualified service personnel only. To reduce the risk of electric shock, do not perform any servicing other than that contained in the operating instructions unless you are qualified to do so.

If You need Help or additional support relating to the contents of this Guide, please contact LAN Power Systems using one of the following methods: Phone: 1-510-275-4572 Fax: 1-510-661-0855 Mail: LAN Power Systems 47835 Westinghouse Drive, Fremont, CA 94539 Web Address: www.lan-power.com Email: support@lan-power.com

Before contacting LPS for technical support, please have the following information ready: Your LPS product model number and unit serial number. A description of the failure or symptoms of problem. A description of any action(s) already taken to resolve the problem (e.g., changing ports, rebooting the unit, etc...). The type of End device being powered including Manufacturer name and part number. Powering requirements of the End device. A description of your Network environment (layout, Ethernet switch description, cable type, etc...). The unit history (i.e., have you returned the unit before, is this a recurring problem, etc...)



Electrical Hazard: Only qualified personnel should install this unit. Read instructions before attempting to install this unit.



Verifying Contents of Package - Unpack the PoE Injector and verify that you have all of the following items: Single Port Power over Ethernet Injector, Power Cord, Wall Mounting bracket and 2 screws.

Technical Considerations - Before you mount the PoE Injector to a fixed location, consider all of the following: Determine optimal placement, check patch cord routing and AC outlet location. Collect and document Network information as required. Ensure the cable length from the Ethernet Network Switch to the Powered End device does not exceed 100 meters total length. **Note:** The PoE Injector is not a repeater and does not amplify the Ethernet data signal. The Injector must be used in conjunction with an Ethernet Switch.

Powering Up and installing the Injector

Plug one end of the power cord into the Injector and the other end into a grounded AC power source. Units are typically connected to a power strip or other power outlet that may be cycled on and off. An uninterruptible power supply (UPS) may be used. This assures uninterrupted power to the End device should there be a loss of building power. Next, attach a LAN data cable patch cord of minimum Cat5 cable grade from the Ethernet Switch port to the RJ45 connector on PoE Injector marked "IN". Then attach a second patch cable from the "OUT" RJ45 connector on the PoE Injector to the structured wiring connection leading to the device to be powered. Turn on power source. The "IN" LED on the Injector will glow "GREEN". If End device to be powered is already installed on Network, the "OUT" LED will glow "GREEN". The PoE Injector is now correctly installed and operating.

Safety Instructions: The means of connection to the mains power supply is the detachable power cord of the equipment. The equipment disconnect device is the appliance inlet. The AC socket outlet shall be installed near the equipment and shall be easily accessible.

LED indicators and functions - The PoE Injector has two LED's which assist with understanding unit operation. LED #1 - Unit Power - The LED glows GREEN if input power is being received properly from AC outlet - This indicates the unit is capable of forwarding power to the End device. LED #2 - Connection to End device and Power forwarding - The LED glows GREEN if detection is achieved with the End device and power is being forwarded out over the Ethernet cable.

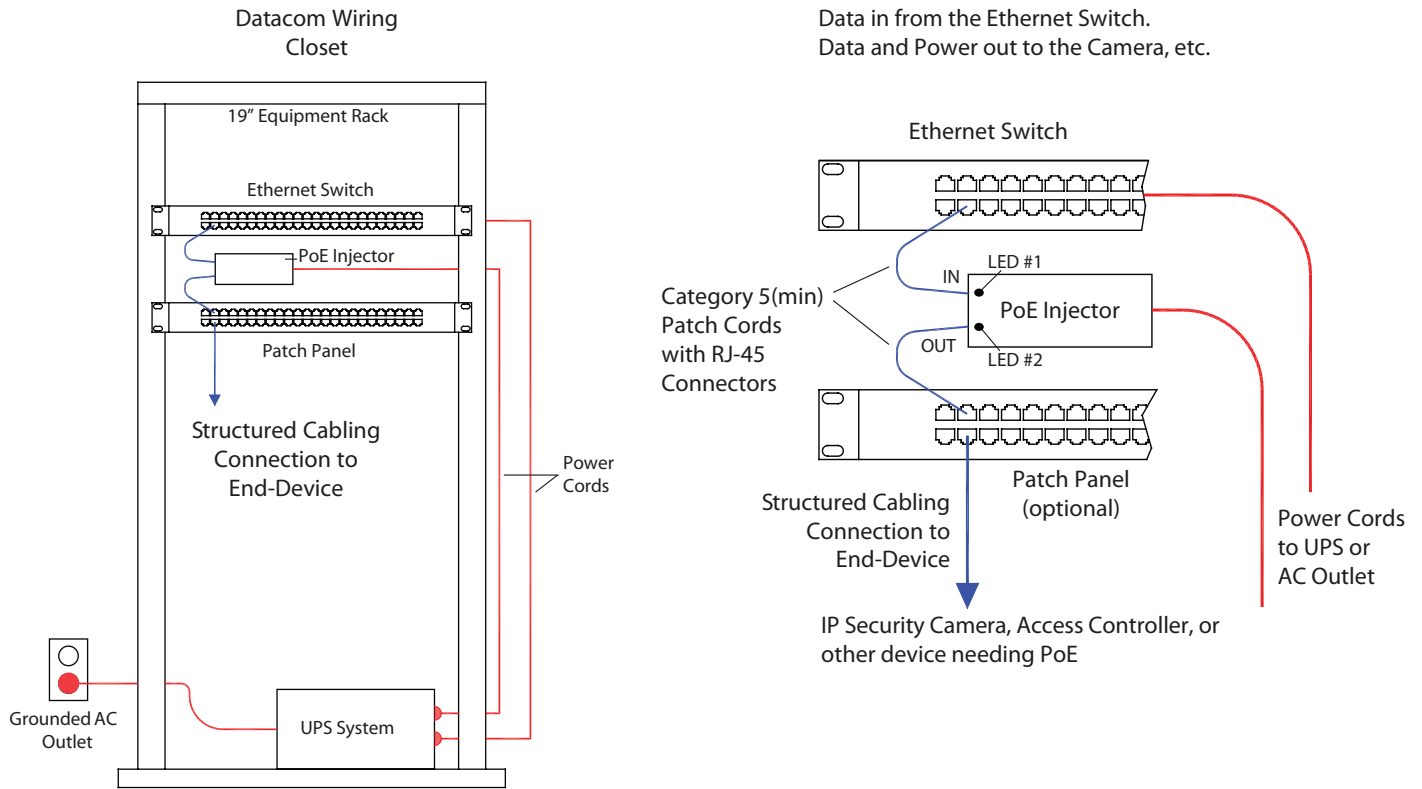

If you need more information on Installing or using this COBRA product, or need PoE troubleshooting advice, see the COBRA Support section of LAN Power Systems website at www.lan-power.com and download the complete online Guide.

Safety Approvals

The equipment meets the following safety approvals:



Two Year Limited Warranty

LPS warrants to the original consumer or purchaser that each of its products, and all components thereof, will be free from defects in material and/or workmanship for a period of 2 years from the original purchase date. Any warranty hereunder is extended only to the original consumer or purchaser and is not assignable. More at www.lan-power.com

Notice to User

LAN Power Systems reserves the right to make changes in specifications and other information contained in this document and its web site without prior notice. The reader should in all cases consult LAN Power Systems to determine whether any such changes have been made. The hardware described in this document is subject to change without notice due to market conditions or user requirements. More at www.lan-power.com